

DEVELOPED FOR INDUSTRIAL DIESEL APPLICATIONS

FAUDI Diesel Vertical Filter Housings (VFH) are designed to meet the tough requirements of industrial diesel applications and provide for ease of installation and service. Close monitoring of fuel quality through storage and on-board filtration is necessary to protect the sensitive injection systems of modern diesel engines. The Vertical Filter Housing (VFH) assembly provides two element options that are available in multiple micron ratings: Coalescer/Separator and Microfilter.

Coalescer/Separator Element The coalescer/separator system consists of two elements to generate a two stage separation process. A coalescer/separator element is to be used to remove free water and fine solids from diesel fuels.

Microfilter A single stage element to remove fine solids and other contaminants from diesel fuels. When contaminated fuel enters the vessel, fine solids are removed down to 2 µm, providing clean fuel to engines or equipment. Micron rating available: 2, 5, 10 & 25 µm.



APPLICATION AREA

- Mining
- Refineries, Terminals & Tank Farms
- Power Generation, Gas Turbines
- Ships, Super Yachts & Marine Loading
- All Bulk Diesel transfer applications

TECHNICAL DATA

- Design pressure (housing): 10 bar (150 psi)
- Flow rates (maximum) Up to 189 lpm (50 USgpm)
- Temperature range: -10°C/+50°C (14°F/122°F)

STANDARD DESIGN

- Material: Die-casting aluminum head, steel filter bowl
- Components: Powder-coated components
- Cover seal: NBR (Buna-N)
- In-/Outlet port: G 1 1/2"
- Locking ring collar
- collarDie-casting

RECOMMENDED ACCESSORIES

- Differential pressure gauge (with scale)
- Manual vent valve
- Manual drain valve
- Sight glass
- Mounting bracket

ORDER REFERENCE

Assembly	Item No.
VFH-1-355-D-G (14")	50230

Micron Rating	Filter Element		Change Out Differential Pressure	Flow Rates	
	Coalescer/ Separator	Microfilter		lpm	USgpm
	Type	Type			
(µm)			bar (psi)		
5, 10, 25	FDCS-614-xx		1,7 bar (25 psi)	90	24
2, 5, 10, 25		FDF-614-xxOR2	1,7 bar (25 psi)	189	50

ORDER REFERENCE

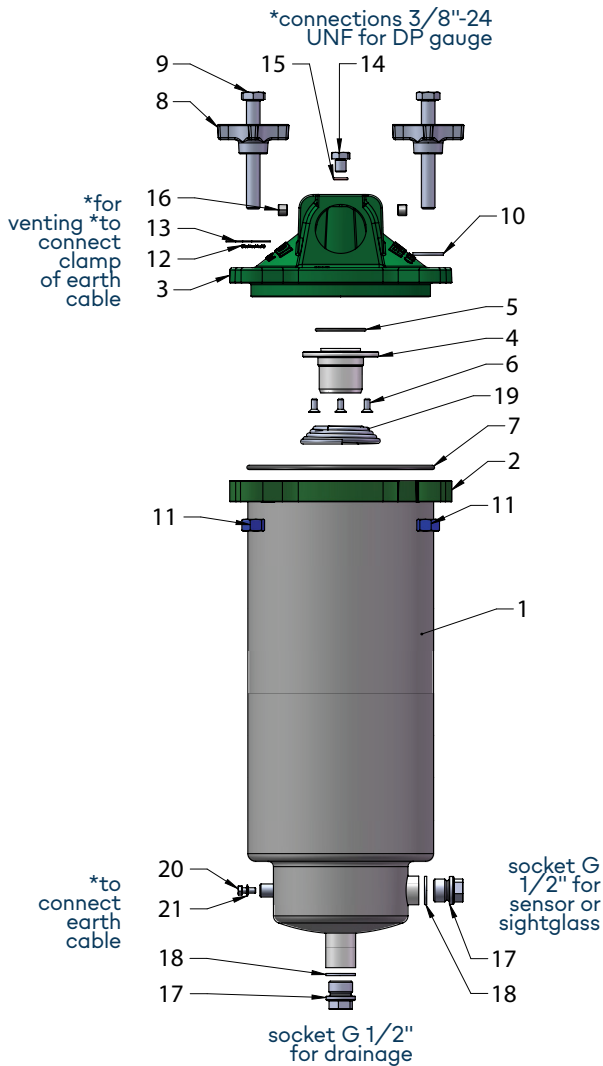

*Optional parts are available

Pos.	Qty.	Description	Item No.
1	1	Bowl VFH-355-10	3013055
2	1	Flange Ring - VFH	50232
3	1	Head - VFH	50228
4	1	VFH + Cartridge Spigot	3013074
5	1	O-Ring $\varnothing 40 \times 2.50$	3013256
6	3	Countersunk Screw M5 \times 12	3013257
7	1	O-Ring $\varnothing 158 \times 4$	3013661
8	4	Cross Handle, M12	3013070
9	4	Hex Bolt M12 \times 100	3006296
10	3	Washer DIN522	3013347
11	4	Hex Nut, M12 coated	2004563
12	1	Lock Washer	3007785
13	1	Washers with Long Tab	9166828
14	2	Plug 3/8"-24 UNF	3013920
15	2	O-Ring $\varnothing 9,52 \times 1,78$	3003831
16	2	Plug G 1/8"	9154428
17	2	Plug G 1/2"	9154451
18	2	Gasket $\varnothing 26 \times 21 \times 2$	8868002
19	1	Conical Spring	3013346
20	1	Hex Bolt M5 \times 12	3013481
21	1	Lock Washer	3013480

